

V-DRIVE AND FRONT ENGINE COUPLINGS

CRANKSHAFT TAKE-OFF WITH V-PULLEY



STEEL

V-Belt pulley groove is an integral part of this power take-off. Perfect for driving a generator or water pump.

FOR INTERNALLY BALANCED ENGINES ONLY. WHEN ORDERING SPECIFY ENGINE.

Drive Line

Series	Catalog No.	Item No.
1310	33821	862
1350	33825	863

CRANKSHAFT TAKE-OFF

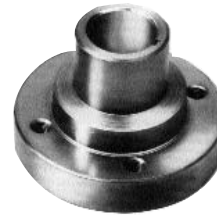

STEEL

Available for most popular automotive engines. Power take-offs used to couple cranking end of engine to drive line.

FOR INTERNALLY BALANCED ENGINES ONLY. WHEN ORDERING SPECIFY ENGINE.

Drive Line

Series	Catalog No.	Item No.
1310	33811	860
1350	33815	861

V-DRIVE FLANGE TAKE-OFF



STEEL

Drive Line Series	Bore Size	Catalog No.	Item No.
1310	1"	33911	86416
1310	1-1/8"	33911	86418
1310	1-1/4"	33911	86420
1310	1-3/8"	33911	86422
1350	1"	33915	86516
1350	1-1/8"	33915	86518
1350	1-1/4"	33915	86520
1350	1-3/8"	33915	86522

BORG WARNER FLANGES



STEEL

Flanges are for the 4" and 5" diameter Borg Warner 71 and 72, EXCEPT the 864-B and 864-E which are for a Casale C-500 ONLY.

Description	Catalog No.	Item No.
1" Male 71 B/W - 4"	339-11A	864-A
1" Male Spicer Casale- 4"	339-11B	864-B
1" Taper Male 71 B/W - 4"	339-11C	864-C
1-1/8" Male 71 B/W - 4"	339-18D	864-D
1-1/8" Male Spicer Casale - 4"	339-18E	864-E
1" Male 72 B/W - 5"	339-11A	865-A
1-1/8" Male 72 - 5"	339-18B	865-B

V-DRIVES

CASALE SPLIT CASE V-DRIVE

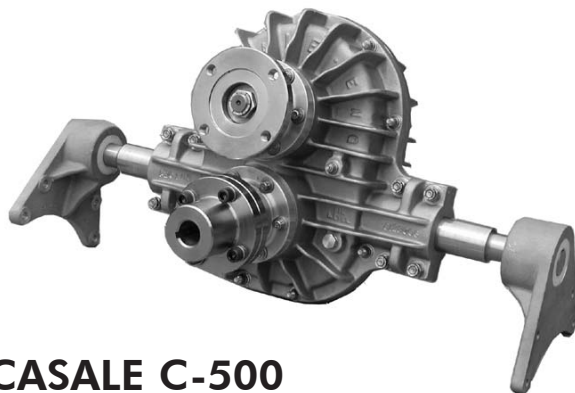

CASALE C-500

A direct drive V-drive for boats where a marine transmission is coupled to the engine. An extra heavy aluminum casting with oversize bearings make this a very quiet gear box. V-drive is equipped with input flange to suit torque tubes or drive lines of our 1310 and 1350 series. The output shaft is equipped with a flange to couple to the prop. Shaft is 1" or 1-1/8" shaft sizes. Comes complete with the mounting bracket on flanges located on the thrust centerline of the V-drive.

Available in Overdrive or Underdrive Gear Ratios of: 1.04, 1.10, 1.15, 1.22 and 1.29.

Catalog No. 355500	Item No. 929
-----------------------	-----------------

NOTE: When ordering please specify: Overdrive or underdrive ratio, 1310 or 1350 series input flange, prop shaft size and mounting spacing desired.

BEARING PULLER

STEEL

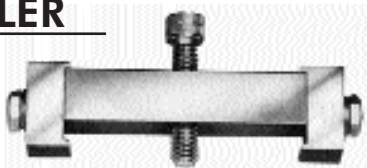

Provides quick and easy removal of bearings in Casale Split Case V-drives.

Catalog No. 36050	Item No. 934
----------------------	-----------------

V-DRIVE GASKET SET

FOR SPLIT CASE V-DRIVES ONLY

Catalog No. CASALE	Item No. 928
-----------------------	-----------------

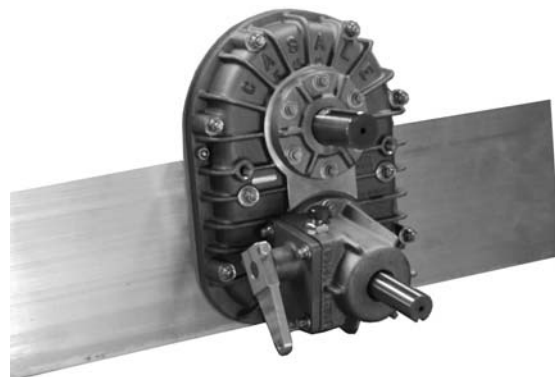

The finest V-Drive for recreation or competition. Features water cooled case, precision cut helical gears, heavy duty ball bearings and a high tensile cast aluminum alloy exterior casing. Available in direct drive or in-and-out configuration.

10 Degree	Catalog No.	Item No.
10° Standard V-Drive	35411	923
10° In-and-Out V-Drive	35420	926
10° Set of Gears	35410	922

Specify ratio and left or right hand gears.

RATIOS (Overdrive)

1.06.....	37-35	1.29.....	40-31
1.09.....	37-34	1.32.....	41-31
1.12.....	38-34	1.37.....	41-30
1.15.....	38-33	1.40.....	42-30
1.18.....	38-32	1.45.....	42-29
1.22.....	39-32	1.48.....	43-29
1.25.....	40-32	1.54.....	43-28

Other ratios available - Special Order Only

Mounting Plate Size: 26"

12° Set of Gears	35412	924
------------------	-------	-----

V-DRIVE SHIFTER

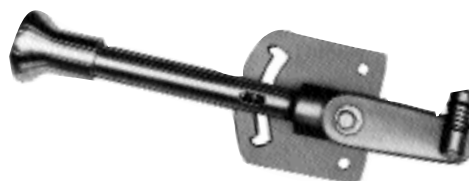

Ratchet type shift selector which keeps V-Drive from sliding out of gear. Applicable for all V-Drives.

Description	Catalog No.	Item No.
In-and-Out	18322	335
In,Out and Reverse	18323	336